



DESIGN:

- Set of 4 cutters and spacers
- With 3 teeth
- Tungsten carbide cutting edges

APPLICATION:

- To cut stile and rail for producing solid wood cabinet doors.
- On shapers

PART NO.	DIAM. ØD	WOOD THICKNESS	BORE ød	NO. TEETH	PROFILE
177AI	4"	3/4" TO 1	1-1/4"	3+3	A
177BI	4"	3/4" TO 1	1-1/4"	3+3	B

Bore can be opened or bushed to spindle size of your machine.

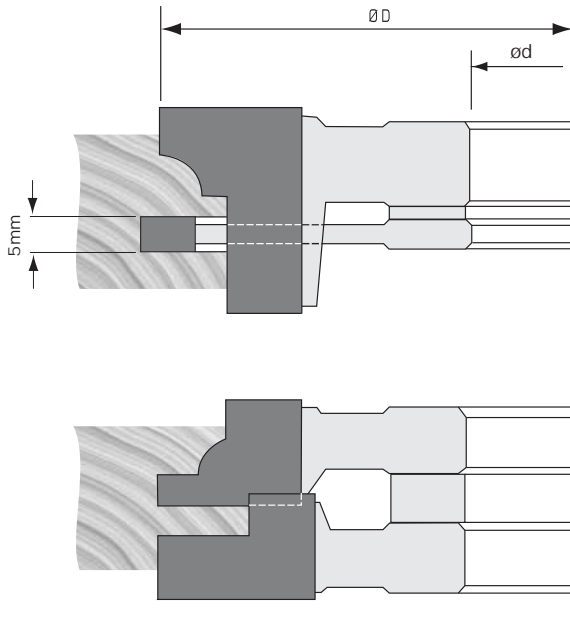

PROFILE A

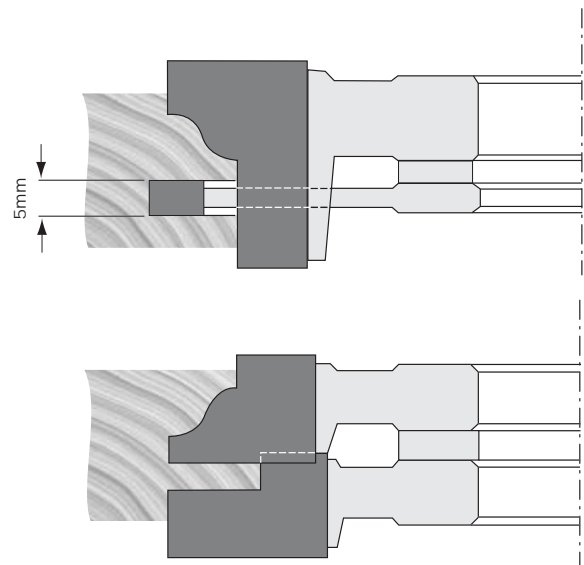
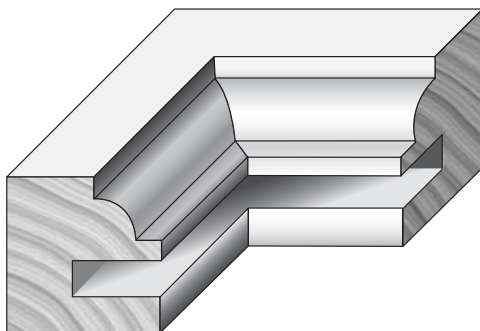

PROFILE B

