**DESIGN:**

- High tensile steel body with 4 teeth
- Available in 22° or 12° hook angle
- Precise serration (60°, 1.6mm pitch) ensures tight and accurate positioning of knives

APPLICATION:

- For profiling of solid woods using HSS knives
- For profiling MDF and other abrasive materials
carbide tipped knives are required
- On moulders

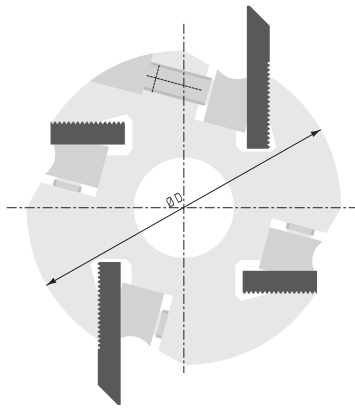

A = 25mm for 4" diam.
A = 28mm for 4-3/4" diam. and over

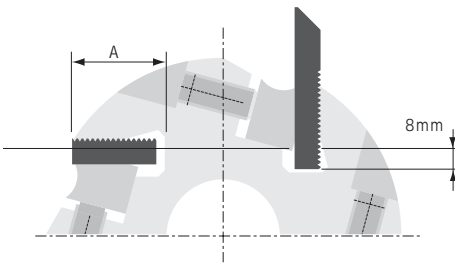

PART NO. 22° HOOK	PART NO. 12° HOOK	DIAM. ØD	KERF B	BORE ød	NO. TEETH	MAX. RPM
18812	N/A	101.6mm 4"	50mm 2"	31.75mm 1-1/4"	4	11000
18813	N/A	101.6mm 4"	76.2mm 3"	31.75mm 1-1/4"	4	11000
18814	N/A	101.6mm 4"	101.6mm 4"	31.75mm 1-1/4"	4	11000
18822	18822-12	122mm 4-3/4"	50mm 2"	38.1mm 1-1/2"	4	9000
18823	18823-12	122mm 4-3/4"	80mm 3-1/8"	38.1mm 1-1/2"	4	9000
18824	18824-12	122mm 4-3/4"	100mm 4"	38.1mm 1-1/2"	4	9000
18825	18825-12	122mm 4-3/4"	130mm 5-1/8"	38.1mm 1-1/2"	4	9000
18826	18826-12	122mm 4-3/4"	150mm 6"	38.1mm 1-1/2"	4	9000
18828	18828-12	122mm 4-3/4"	180mm 7"	38.1mm 1-1/2"	4	9000
18830	18830-12	122mm 4-3/4"	230mm 9"	38.1mm 1-1/2"	4	9000
18832	18832-12	122mm 4-3/4"	50mm 2"	40mm 1.575"	4	9000
18833	18833-12	122mm 4-3/4"	80mm 3-1/8"	40mm 1.575"	4	9000
18834	18834-12	122mm 4-3/4"	100mm 4"	40mm 1.575"	4	9000
18835	18835-12	122mm 4-3/4"	130mm 5-1/8"	40mm 1.575"	4	9000
18836	18836-12	122mm 4-3/4"	150mm 6"	40mm 1.575"	4	9000
18837	18837-12	122mm 4-3/4"	180mm 7"	40mm 1.575"	4	9000
18839	18839-12	122mm 4-3/4"	230mm 9"	40mm 1.575"	4	9000

continued on C11...

...continued from C10

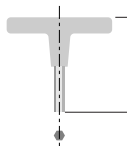
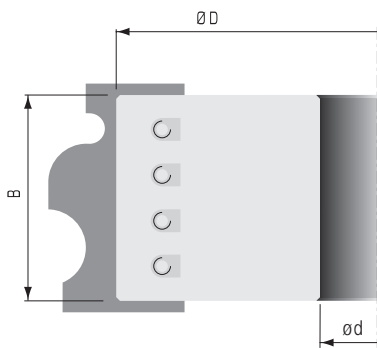

T-HANDLE ALLEN WRENCH
PART NO. W400115 5mm

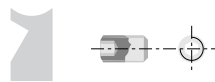

Replacement Parts

TOOLHEAD KERF	WEDGE PART NO.	WEDGE SCREW PART NO.
50mm (2")	W301104	W501305
80mm (3-1/8")	W301107	W501305
100mm (4")	W301109	W501305
130mm (5-1/8")	W301112	W501305
150mm (6")	W301114	W501305
180mm (7")	W301117	W501305
230mm (9")	W301122	W501305

PART NO. 22° HOOK	PART NO. 12° HOOK	DIAM. ØD	KERF B	BORE ød	NO. TEETH	MAX. RPM
18842	18842-12	122mm 4-3/4"	50mm 2"	46.04mm 1-13/16"	4	9000
18843	18843-12	122mm 4-3/4"	80mm 3-1/8"	46.04mm 1-13/16"	4	9000
18844	18844-12	122mm 4-3/4"	100mm 4"	46.04mm 1-13/16"	4	9000
18845	18845-12	122mm 4-3/4"	130mm 5-1/8"	46.04mm 1-13/16"	4	9000
18846	18846-12	122mm 4-3/4"	150mm 6"	46.04mm 1-13/16"	4	9000
18852	18852-12	137mm 5-3/8"	50mm 2"	46.04mm 1-13/16"	4	8000
18853	18853-12	137mm 5-3/8"	80mm 3-1/8"	46.04mm 1-13/16"	4	8000
18854	18854-12	137mm 5-3/8"	100mm 4"	46.04mm 1-13/16"	4	8000
18855	18855-12	137mm 5-3/8"	130mm 5-1/8"	46.04mm 1-13/16"	4	8000
18856	18856-12	137mm 5-3/8"	150mm 6"	46.04mm 1-13/16"	4	8000
18857	18857-12	137mm 5-3/8"	180mm 7"	46.04mm 1-13/16"	4	8000
18859	18859-12	137mm 5-3/8"	230mm 9"	46.04mm 1-13/16"	4	8000
18862	18862-12	137mm 5-3/8"	50mm 2"	40mm 1.575"	4	8000
18863	18863-12	137mm 5-3/8"	80mm 3-1/8"	40mm 1.575"	4	8000
18864	18864-12	137mm 5-3/8"	100mm 4"	40mm 1.575"	4	8000
18865	18865-12	137mm 5-3/8"	130mm 5-1/8"	40mm 1.575"	4	8000
18866	18866-12	137mm 5-3/8"	150mm 6"	40mm 1.575"	4	8000
18867	18867-12	137mm 5-3/8"	180mm 7"	40mm 1.575"	4	8000
18869	18869-12	137mm 5-3/8"	230mm 9"	40mm 1.575"	4	8000

Other sizes available upon request.