

DESIGN:

- High tensile steel body with 4 or 6 straight teeth
- Reversible tungsten carbide inserts with 2 cutting edges

APPLICATION:

- For flush trimming solid wood, veneer, and plastic edge bands
- On single and double edgebanders

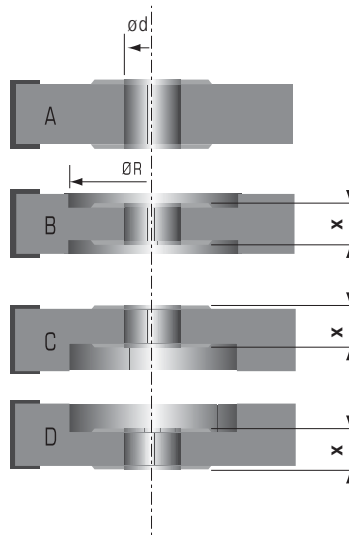
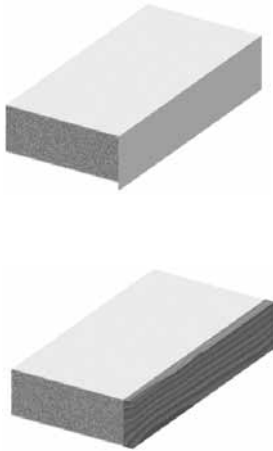

SPECIAL PRODUCTION

DIAM. RANGE ØD mm	KERF B mm	NO. TEETH
50 to 70	15	4
50 to 70	20	4
50 to 70	30	4
71 to 80	15	4
71 to 80	20	4
71 to 80	30	4
81 to 100	15	4
81 to 100	20	4
81 to 100	30	4
50 to 70	15	6
50 to 70	20	6
50 to 70	30	6
71 to 80	15	6
71 to 80	20	6
71 to 80	30	6
81 to 100	15	6
81 to 100	20	6
81 to 100	30	6

WHEN ORDERING SPECIFY:

- CUTTER TYPE (A,B,C or D)
- DIMENSION X
- RECESS ØR (Recess Diameter)
- Keyway Dimensions

Replacement Parts							
DESCRIPTION	KNIFE	KNIFE	KNIFE	WEDGE	WEDGE	WEDGE	WEDGE SCREW
PART NO.	301500	302000	303000	W300203	W300204	W300205	W501301
DIMENSIONS	15x12x1.5	20x12x1.5	30x12x1.5	13	18	28	M6x12

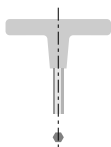

T-HANDLE ALLEN WRENCH
PART NO. W400113 3mm

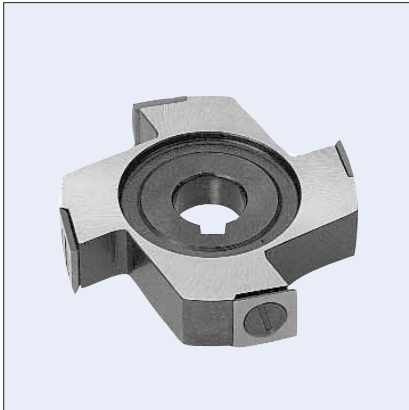
**DESIGN:**

- High tensile steel body with 4 straight cutting edges
- Reversible tungsten carbide inserts with 4 cutting edges

APPLICATION:

- For flush trimming solid wood, veneer, and plastic edge bands
- On HOMAG and EMA edgebanders

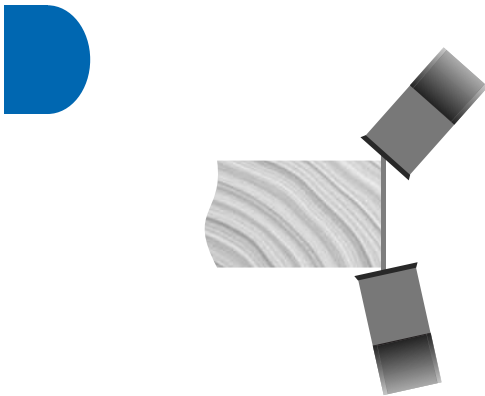
**SPECIAL PRODUCTION**

DIAM. ØD mm	KERF B mm	MAX BORE ød mm	NO. TEETH
70	14	22	4

WHEN ORDERING SPECIFY:

- CUTTER TYPE (A,B,C or D)
- DIMENSION X
- RECESS ØR (Recess Diameter)

Also available in "HSK 25R" for HOMAG and IMA edgebanders.

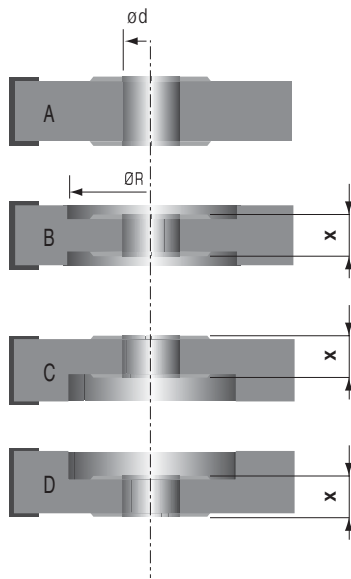
**Replacement Parts**

DESCRIPTION	SPUR	SPUR SCREW
PART NO.	301404	W500002
DIMENSIONS	14x14x2	M5x7

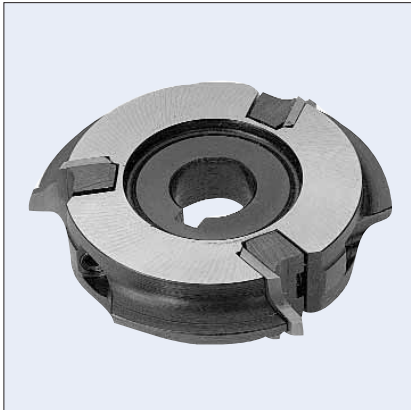

DESIGN:

- High tensile steel body with 3 straight teeth
- Disposable tungsten carbide inserts
- For right and left hand rotation

APPLICATION:

- For rounding of edge bands in solid wood and plastic edges
- On single and double edgebanders

SPECIAL PRODUCTION

DIAM. ØD mm	KERF B mm	MIN. DIAM. mm	MAX BORE ød mm	NO. TEETH
73	16	61	22	3
83	16	70	25	3

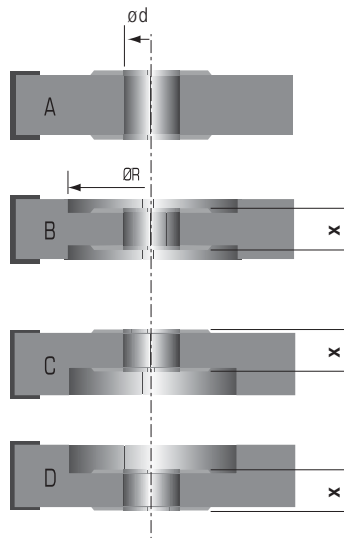
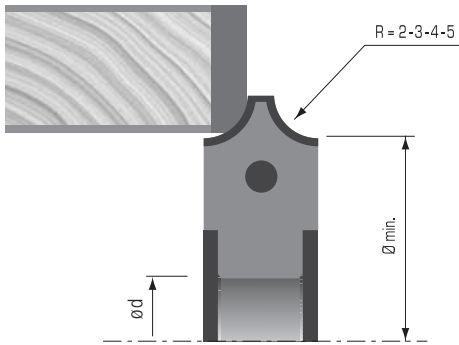

WHEN ORDERING SPECIFY:

- CUTTER TYPE (A,B,C or D)
- DIMENSION X
- RECESS ØR (Recess Diameter)
- RADIUS R

Replacement Parts						
DESCRIPTION	WEDGE	KNIFE R2	KNIFE R3	KNIFE R4	KNIFE R5	WEDGE SCREW
PART NO.	W302503	401002	401003	401004	401005	W501301
DIMENSIONS	15	16x17.5x2	16x17.5x2	16x17.5x2	16x17.5x2	M6x12

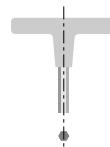

T-HANDLE ALLEN WRENCH
PART NO. W400113 3mm