

1T560 CORNER ROUNDING TOOLHEADS



DESIGN:

- High tensile steel body with 3 teeth on a shear angle
- Disposable tungsten carbide insert knives

APPLICATION:

- For producing quarter round edges in solid wood and panel materials
- On shapers and double-end tenoners

PART NO.	DIAM. ØD mm	KERF B mm	RADIUS R	BORE ød	MAX. BORE mm	NO. TEETH	RPM MIN.-MAX.
1T5601M	124	20	1/4"	1-1/4"	50	3	6100-10600
1T5603M	124	20	3/8"	1-1/4"	50	3	6100-10600
1T5605M	143	30	1/2"	1-1/4"	50	3	5300-9100
1T5607M	143	30	5/8"	1-1/4"	50	3	5300-9100
1T5608M	143	30	3/4"	1-1/4"	50	3	5300-9100

Other sizes available upon request.

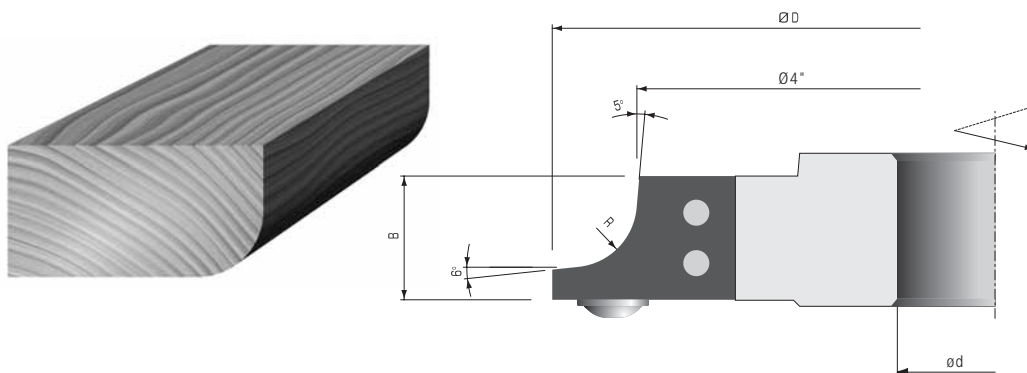

Replacement Parts

TOOL NO.	DESCRIPTION	KNIFE	WEDGE	WEDGE SCREW
1T5601M	PART NO.	1T560A	W070761	W501404
	DIMENSIONS	15x25x2	17.6x11x9.5	M8x20
1T5603M	PART NO.	1T560B	W070761	W501404
	DIMENSIONS	20x25x2	17.6x11x9.5	M8x20
1T5605M	PART NO.	1T560C	W049971	W501316
	DIMENSIONS	20x30x2	27x11x9.5	M6x20
1T5607M	PART NO.	1T560D	W049971	W501316
	DIMENSIONS	25x30x2	27x11x9.5	M6x20
1T5608M	PART NO.	1T560E	W049971	W501316
	DIMENSIONS	30x35x2	27x11x9.5	M6x20

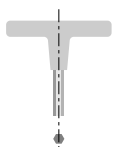

T-HANDLE ALLEN WRENCH
PART NO. W400115 5mm