

1T595 WINDOW TOOLING



DESIGN:

- High tensile steel body with tungsten carbide insert knives
- Tools custom manufactured to customer's specifications

APPLICATION:

- For producing window components in solid wood
- On single and double-end tenoners

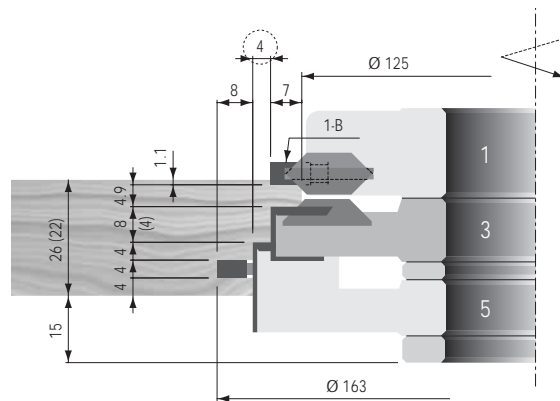
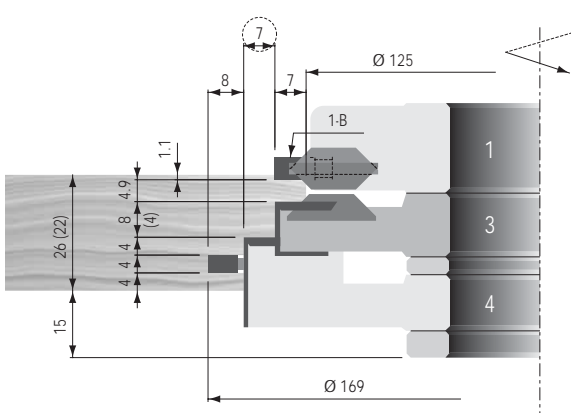
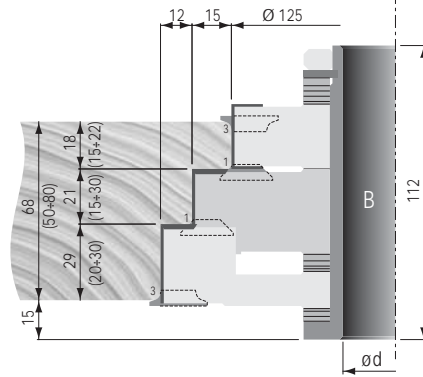
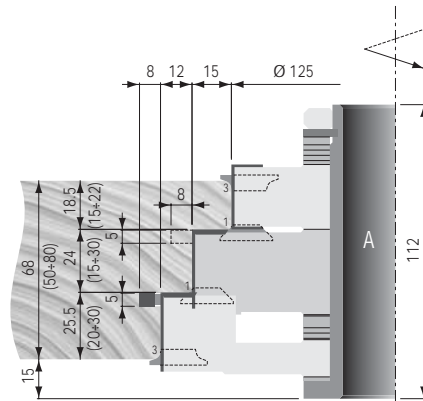

1T595 WINDOW TOOLING

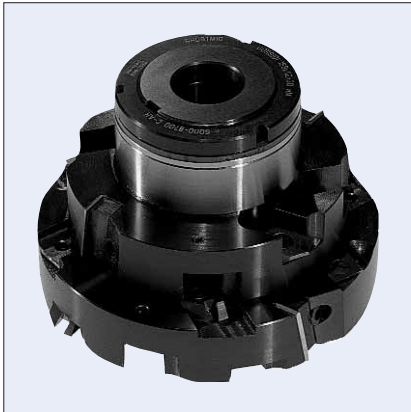

DESIGN:

- High tensile steel body with tungsten carbide insert knives
- Tools custom manufactured to customer's specifications

APPLICATION:

- For producing window components in solid wood
- On moulders

