**DESIGN:**

- Standard set consists of two outside saw blades 1/8" kerf, one 1/4" chipper, two 1/8" chippers and one 1/16" chipper
- Cutting material: TC

**APPLICATION:**

- To cut grooves and dados in soft and hardwoods, plywood and veneered panels
- Groove widths adjustable from 1/4" to 13/16" maximum width in 1/16" increments. Wider grooves can be obtained by adding spare chippers
- On table saws, sliding table saws and single or double end tenoners

PART NO.	DIAM.	MAX. WIDTH	BORE	TEETH
53DL06	6"	13/16"	5/8"	24
53DL08	8"	13/16"	5/8"	24
53DL08-1	8"	13/16"	1"	24
53DL10	10"	13/16"	5/8"	24
53DL10-1	10"	13/16"	1"	24
53DL12	12"	13/16"	1"	24
53DL14	14"	13/16"	1"	40

**OUTSIDE SAW BLADES ONLY**

PART NO.	DIAM.	KERF	BORE	TEETH
53DL06-LH/RH	6"	1/8"	5/8"	24
53DL08-LH/RH	8"	1/8"	5/8"	24
53DL08-1-LH/RH	8"	1/8"	1"	24
53DL10-LH/RH	10"	1/8"	5/8"	24
53DL10-1-LH/RH	10"	1/8"	1"	24
53DL12-LH/RH	12"	1/8"	1"	24
53DL14-LH/RH	14"	1/8"	1"	40

**SPARE CHIPPERS 2-TEETH**

PART NO.	KERF	PART NO.	KERF	PART NO.	KERF	DIAM.	BORE
5306-16	1/16"	5306-18	1/8"	5306-14	1/4"	6"	5/8"
5308-16	1/16"	5308-18	1/8"	5308-14	1/4"	8"	5/8"
5308-16-1	1/16"	5308-18-1	1/8"	5308-14-1	1/4"	8"	1"
5310-16	1/16"	5310-18	1/8"	5310-14	1/4"	10"	5/8"
5310-16-1	1/16"	5310-18-1	1/8"	5310-14-1	1/4"	10"	1"
5312-16	1/16"	5312-18	1/8"	5312-14	1/4"	12"	1"
5314-16	1/16"	5314-18	1/8"	5314-14	1/4"	14"	1"

## 53DLS SAFETY DADO SETS "ANTI-KICKBACK" DESIGN

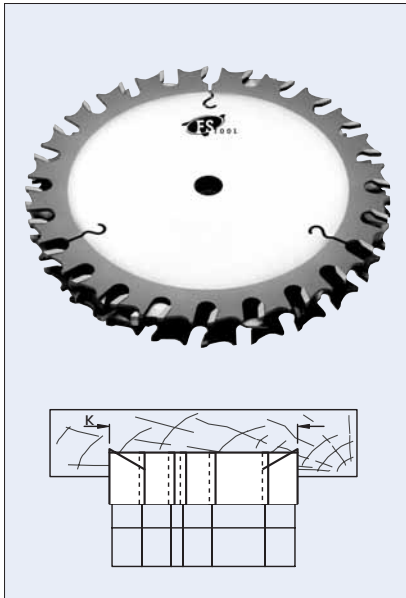

### DESIGN:

- Standard set consists of two outside saw blades 1/8" kerf, one 1/4" chipper, two 1/8" chippers and one 1/16" chipper
- "Anti-kickback" design reduces the risk of kick-back
- Cutting material: TC

### APPLICATION:

- To cut grooves and dados in soft and hardwoods, plywood and veneered panels
- Groove widths adjustable from 1/4" to 13/16" maximum width in 1/16" increments. Wider grooves can be obtained by adding spare chippers
- On table saws, sliding table saws and single or double end tenoners

PART NO.	DIAM.	MAX. WIDTH	BORE	TEETH
53DL08S	8"	13/16"	5/8"	24

### OUTSIDE SAW BLADES ONLY

PART NO.	DIAM.	KERF	BORE	TEETH
53DL08S-LH/RH	8"	1/8"	5/8"	24

### SPARE CHIPPERS 2-TEETH

PART NO.	KERF	PART NO.	KERF	PART NO.	KERF	DIAM.	BORE
5308-16S	1/16"	5308-18S	1/8"	5308-14S	1/4"	8"	5/8"

## 54DL FINE DADO SETS

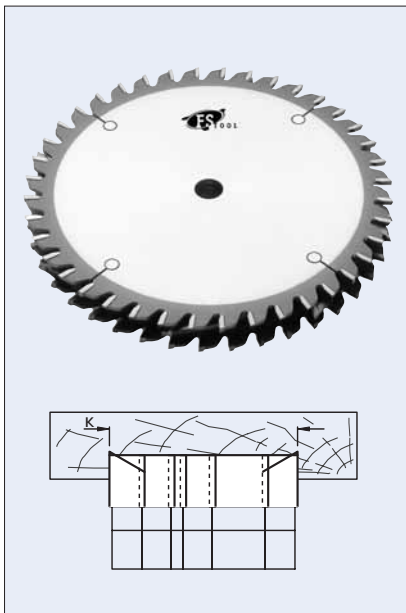

### DESIGN:

- Standard set consists of two outside saw blades 1/8" kerf, one 1/4" chipper, two 1/8" chippers and one 1/16" chipper
- Cutting material: TC
- Hook angle: 0°

### APPLICATION:

- To cut grooves and dados in plastic laminated panels
- Groove widths adjustable from 1/4" to 13/16" maximum width in 1/16" increments. Wider grooves can be obtained by adding spare chippers
- On table saws, sliding table saws and single or double end tenoners

PART NO.	DIAM.	MAX. WIDTH	BORE	TEETH
54DL08	8"	13/16"	5/8"	40
54DL08-1	8"	13/16"	1"	40
54DL10	10"	13/16"	5/8"	60
54DL10-1	10"	13/16"	1"	60

### OUTSIDE SAW BLADES ONLY

PART NO.	DIAM.	KERF	BORE	TEETH
54DL08-LH/RH	8"	1/8"	5/8"	40
54DL08-1-LH/RH	8"	1/8"	1"	40
54DL10-LH/RH	10"	1/8"	5/8"	60
54DL10-1-LH/RH	10"	1/8"	1"	60

Spare Chippers: see page E44