

R2541 "V" GROOVING BITS
90° INCLUDED ANGLE

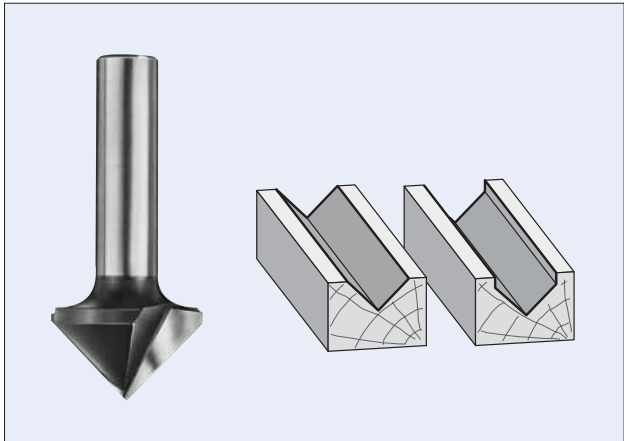

PART NO.	CUTTING DIAM.	CUTTING DEPTH	SHANK DIAM.	OVERALL LENGTH
R2541	3/8"	1/2"	1/4"	1-3/4"
R2541-1	3/8"	1/2"	1/2"	1-3/4"
R2542	1/2"	1/2"	1/4"	1-3/4"
R2542-1	1/2"	1/2"	1/2"	2-1/8"
R2543	5/8"	1/2"	1/4"	1-3/4"
R2543-1	5/8"	1/2"	1/2"	2-1/8"
R2543-2	3/4"	5/8"	1/4"	1-3/4"
R2544	3/4"	5/8"	1/2"	2-1/4"
R2544-1	7/8"	5/8"	1/4"	2"
R2544-2	7/8"	5/8"	1/2"	2-1/4"
R2545	1"	3/4"	1/4"	1-3/4"
R2545-1	1"	3/4"	1/2"	2-3/8"
R2546	1-1/4"	1"	1/2"	2-1/2"
R2547	1-1/2"	1-1/4"	1/2"	2-7/8"
R2548	1-3/4"	1-1/2"	1/2"	3"
R2549	2"	1-3/4"	1/2"	3"

R2550 "V" GROOVING BITS
60°/70° INCLUDED ANGLE

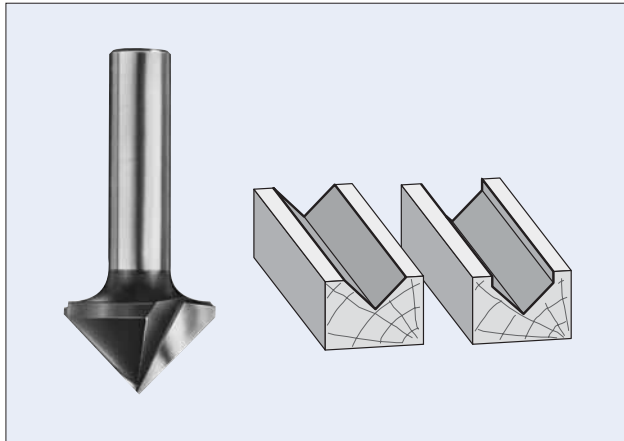

PART NO.	CUTTING DIAM.	INCLUDED ANGLE	CUTTING DEPTH	SHANK DIAM.	OVERALL LENGTH
R2550	1/2"	60°	1/2"	1/4"	1-3/4"
R2551	1/2"	70°	1/2"	1/4"	1-3/4"

R2560 "V" GROOVING BITS
WITH BEARING GUIDE 90°

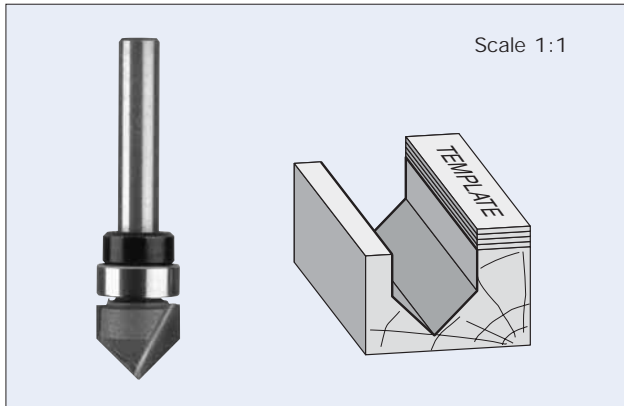

PART NO.	CUTTING DIAM.	CUTTING DEPTH	SHANK DIAM.	OVERALL LENGTH
R2560	1/2"	1/2"	1/4"	2"

Replacement Parts
(A) Ball Bearing B3-1 Lock Ring W01 Screw WNC525

