

**R2631 TEE/BUMPER MOULDING GROOVING BITS TWO FLUTES**

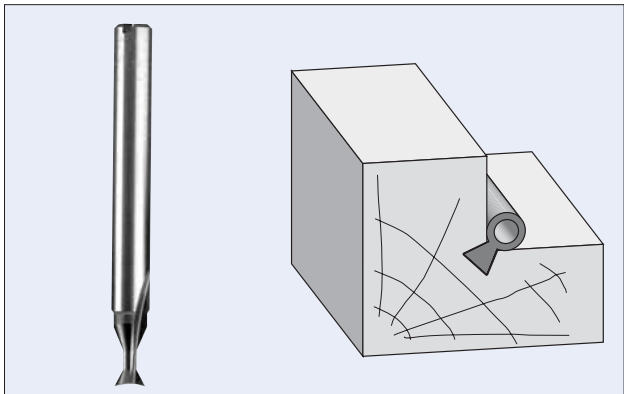

PART NO.	LARGE DIAM.	DEGREES EA. SIDE	DEPTH OF CUT	SHANK DIAM.	OVERALL LENGTH
R2631	13/64"	25°	5/32"	1/4"	2-3/8"

**R2632 TEE/BUMPER MOULDING GROOVING BITS TWO FLUTES**

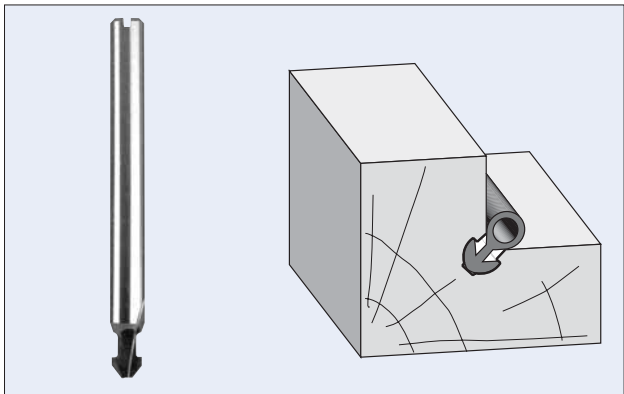

PART NO.	LARGE DIAM.	SMALL DIAM.	DEGREES EA. SIDE	DEPTH OF CUT	SHANK DIAM.	OVERALL LENGTH
R2632	7/32"	5/64"	38°	5/16"	1/4"	2-9/16"

**R2700 PANEL PILOT BITS WITH PLUNGE POINT**

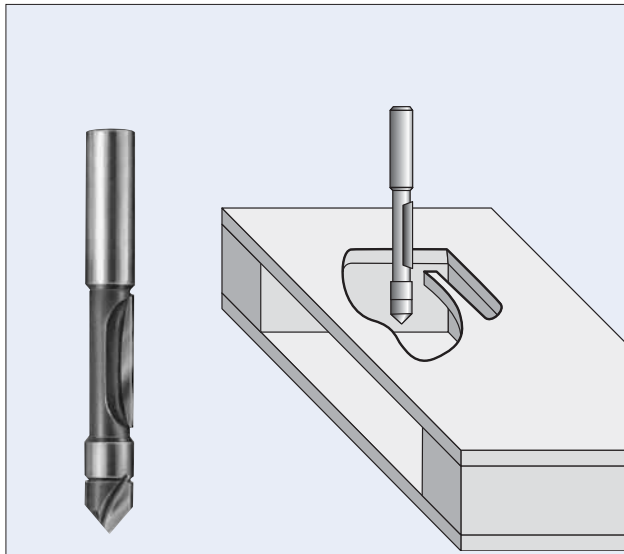

PART NO.	CUTTING DIAM.	CUTTING LENGTH	SHANK DIAM.	FLUTES	OVERALL LENGTH
R2700	1/4"	3/4"	1/4"	1	2-1/2"
R2701	3/8"	1"	3/8"	1	3"
R2702	1/2"	1-3/16"	1/2"	1	3-1/2"
R2703	1/2"	2"	1/2"	1	4-1/2"
R2704	3/8"	1"	1/4"	2	3"
R2705	3/8"	1"	3/8"	2	3"
R2706	1/2"	1-1/4"	1/2"	2	3-3/4"
R2707	1/2"	2"	1/2"	2	4-1/2"

**R2710 SOLID CARBIDE ENGRAVING BITS THREE FLUTES**

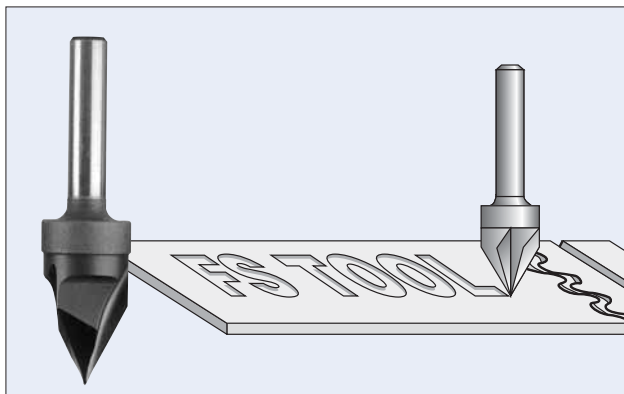

PART NO.	CUTTING DIAM.	CUTTING DEPTH	SHANK DIAM.	OVERALL LENGTH
R2710	9/16"	7/8"	1/4"	2-1/4"